

MOBILE CRANE BEFARD DG



**ELECTRIC ACCUMULATOR PICK
AND CARRY CRANE**

MOBILE CRANE WHEELED "PICK AND CARRY" TYPE BEFARD DG 620/ DG 820

BEFARD DG 620 / DG 820 "Pick and Carry" mobile crane.
It is used to carry heavy loads. It is very suitable for work with injection and casting moulds as well as in factory halls where there is a need to replace/ assemble elements in tight spaces without the possibility of using a forklift.

OPTIONAL EXTRAS

- Headstock with hydraulic side shift and tilt
- Non-marking solid wheels instead of black, pumped wheels
- Side-support deployment sensor
- Remote (radio) control of arm and optional head
- Folding handle (reduces the length of the machine for transportation e. g. by lift)
- Forklift forks
- Hydraulic winch

PARAMETERS BEFARD DG 620/ DG 820

- One, two or three hydraulic extensions with a total reach of 3. 40 m/4. 15 m/4. 75 m,
- two supports - right and left side,
- maximum load capacity
- BEFARD DG 620 - 620 kg - maximum two extensions,
- BEFARD DG 820 - 820 kg - maximum three extensions,
- battery-powered,
- colour of your choice,
- Weight approx. 900 kg (depending on versior
- Overload protection system

Remote control as an optional extra



MOBILE CRANE BEFARD DG OPTIONAL EXTRAS

Optional head with (Pic. 1) :

- manual tilting right-left 45° and 90° pic. - 2 and 3
- hydraulic clockwise and counterclockwise tilt from 0° to 90° on request
- hydraulic tilt up and down pic. - 4 and 5
- hydraulic lateral displacement 10 cm - (pic. 6)



MOBILE CRANE BEFARD DG OPTIONAL EXTRAS

Forks



Folding handle



Hydraulic winch

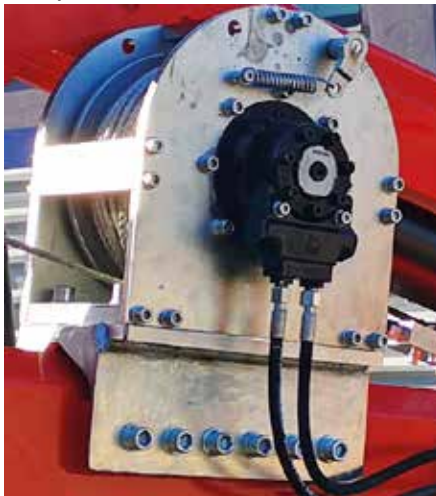

MOBILE CRANE BEFARD DG

OPTIONAL EXTRAS

Non-marking solid wheels (Pic. 1.)



Wheels also available as an option with black tyres filled with elastomer - unpunctured wheels (Pic. 2.)

MOBILE CRANE BEFARD DG 620/ DG 820

ONE-EXTENSION

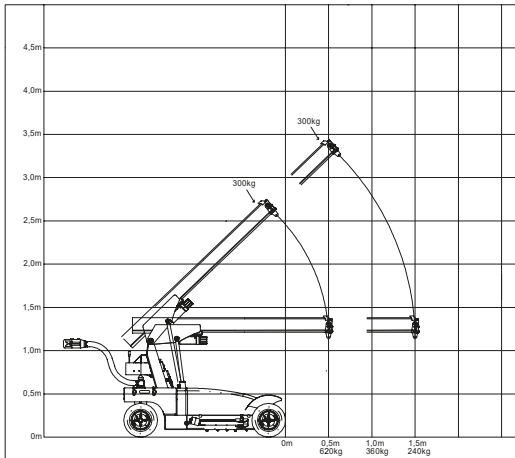
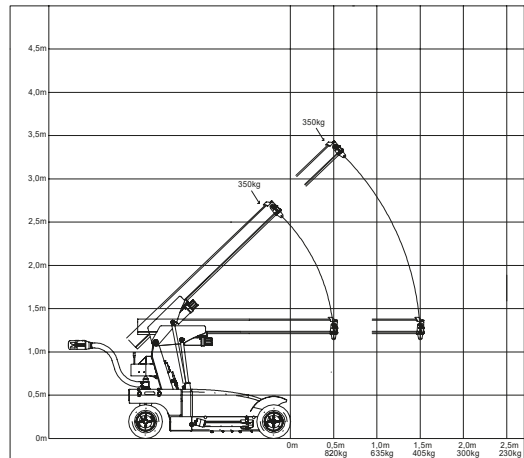
**BEFARD DG 620****BEFARD DG 820**

MOBILE CRANE BEFARD DG 620/ DG 820

WITH ONE EXTENSION AND HEAD



BEFARD DG 620 WITH HEAD WITH LATERAL MOVEMENT AND HYDRAULIC TILT

BEFARD DG 820 WITH HEAD WITH LATERAL MOVEMENT AND HYDRAULIC TILT

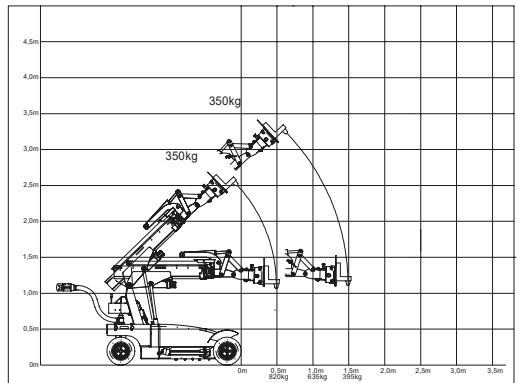
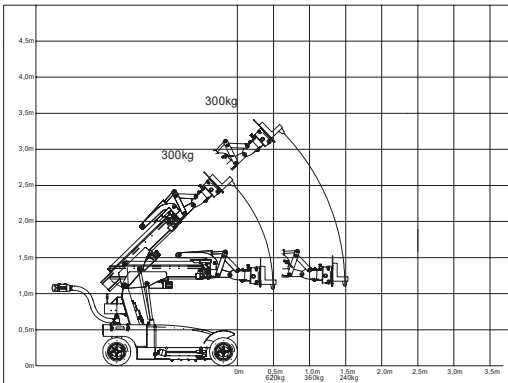

MOBILE CRANE BEFARD DG 620/ DG 820

WITH TWO PULL-OUTS



BEFARD DG 620

BEFARD DG 820

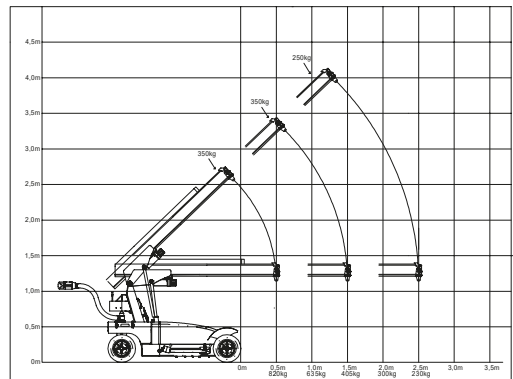
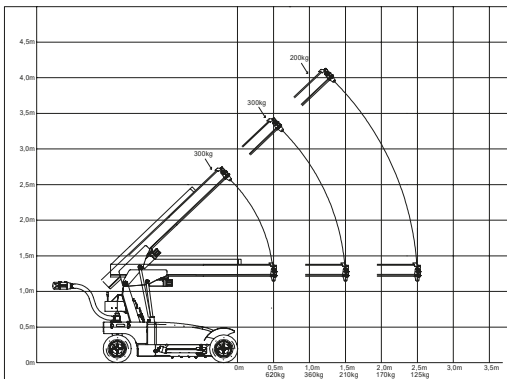

MOBILE CRANE BEFARD DG 620/ DG 820

WITH TWO EXTENSIONS AND A HEAD



BEFARD DG 620 WITH SIDE SHIFT HEAD AND HYDRAULIC TILT

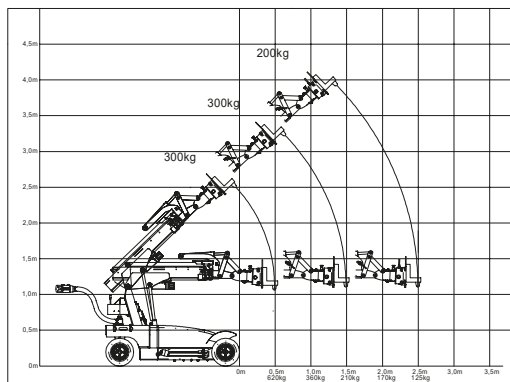

BEFARD DG 820 WITH SIDE-SHIFT HEAD AND HYDRAULIC TILT

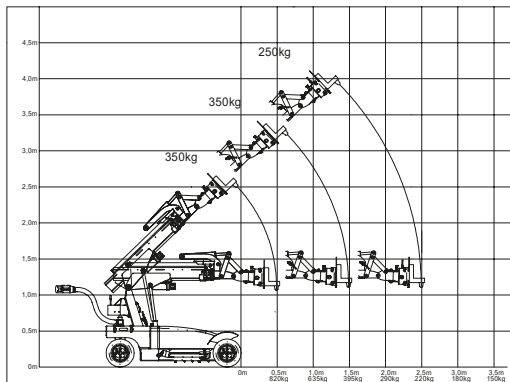

MOBILE CRANE BEFARD DG 820

WITH THREE EXTENSIONS

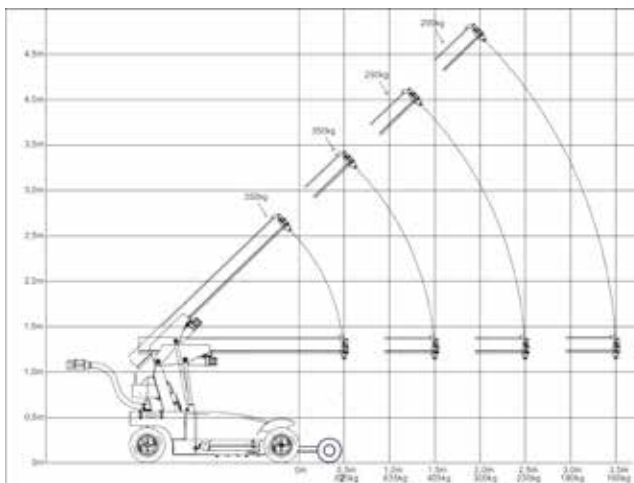

MOBILE CRANE BEFARD DG 820 WITH THREE EXTENSIONS AND HEAD

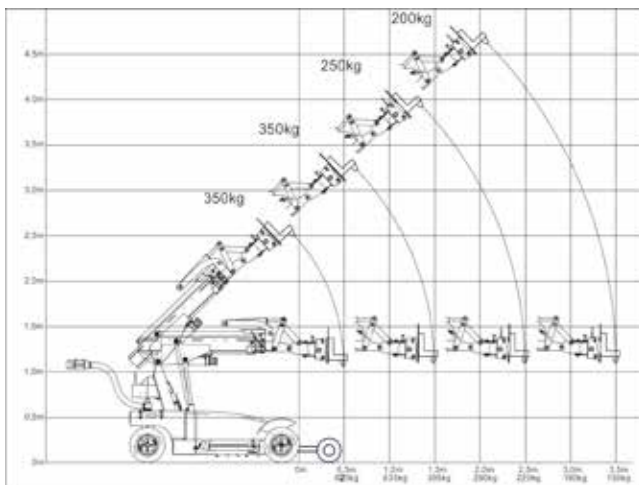

MOBILE CRANE BEFARD DG 620/ DG 820



MOBILE CRANE BEFARD DG 620/ DG 820

TRANSPORT POSITION

